

FAS 8 mm CHIPSOL MS

Direct acting solenoid valve

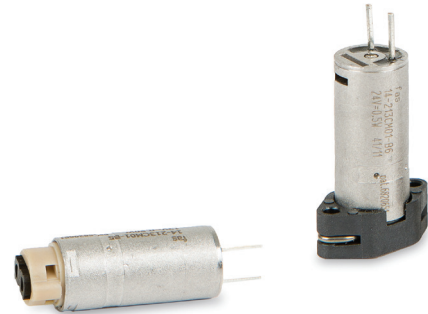

- > **2/2 NC**
Media separated
Cartridge or manifold mounting
- > **Low internal volume,**
virtually no unswept volume
- > **Very compact design**
(\varnothing 8 x 21 mm)
- > **Low power consumption (0,5 W)**
- > **Long life up to 30 million cycles**
- > **100% E.D. operation up to 50°C fluid temperature**



Technical features

Medium:

Neutral or aggressive gases and liquids

Operation:

Direct acting 2-way valves, normally closed

Operating pressure:

0 ... 2,1 bar (0 ... 30 psi) at port 1
0 ... 0,2 bar (0 ... 2,9 psi) at port 2
0,5 bar (7,2 psi) maximum back pressure at port 2

Mounting:

Cartridge or manifold

Size:

8 mm

Flow characteristics:

Orifice size: 0,8 mm

kv: 0,1 (Cv: 0,007)

Response time:

< 15 ms

Response time measured according to ISO 12238

Life expectancy:

\geq 30 Mio. cycles

Ambient/media temperature:

-10 ... +50°C (+14 ... +122°F)

Air supply must be dry enough to avoid ice formation at temperatures below +2°C (+35°F).

Material:

Body in contact with media: PEEK
Seat seals: EPDM or FFPM

Electrical details

Voltage	12 & 24 V d.c.
Rating	100% E.D.
Voltage tolerance	\pm 10%
Power consumption	0,5 W
Electrical insulation	500 V a.c.
Insulation class	F (155°C)

Following options on request

kv
Operating pressure
Medium temperature
Ambient temperature
Power consumption
Electric connection
Voltage (3, 5 or 6 V d.c.)
Manifold for cartridge version
Sub-base material

Pulse width modulation (PWM) control

A PWM can be used to control the valve and should be set as follows:

	Definition	Value to be applied
Hit voltage	Voltage used for the valve to commute	Valve nominal voltage
Holding voltage	Voltage applied to the valve after commutation	Set duty cycle to guarantee specified holding voltage. 50% of nominal voltage can be used if no value specified.
Hit time	Maximum time required to ensure full valve commutation	40 ms at T > 15°C *1)
PWM frequency		~20 kHz

*1) Please contact us for application outside of those conditions.

Technical data – standard models

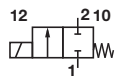
Symbol	Mounting option	Voltage (V d.c.)	Seal Material	Drawing No.	Model
	Manifold	12	EPDM	2	14-213EM01-B5+AWF
	Manifold	12	FFPM	2	14-213EM01-B6+AWF
	Cartridge	12	EPDM	1	14-213CM01-B5+AWF
	Cartridge	12	FFPM	1	14-213CM01-B6+AWF
	Manifold	24	EPDM	2	14-213EM01-B5+AYJ
	Manifold	24	FFPM	2	14-213EM01-B6+AYJ
	Cartridge	24	EPDM	1	14-213CM01-B5+AYJ
	Manifold	24	FFPM	1	14-213CM01-B6+AYJ

Accessories

Manifold (PEEK)



Page 3

S141.0387 *2)

S140.0362 (1/4-28 UNF ports)

*2) Two valve mounting screws are in scope of delivery

Electrical connection

300 mm flying leads mounted with 4 mm (or 2 x 2 mm) pitch SIL socket housing (Harwin M22-3010300)

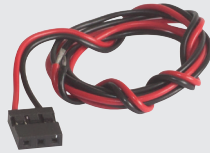

S141.0466

Typically flow rate vs back pressure

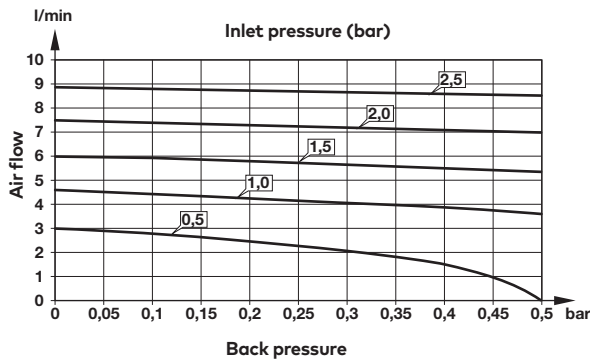

Typically flow rate vs back pressure

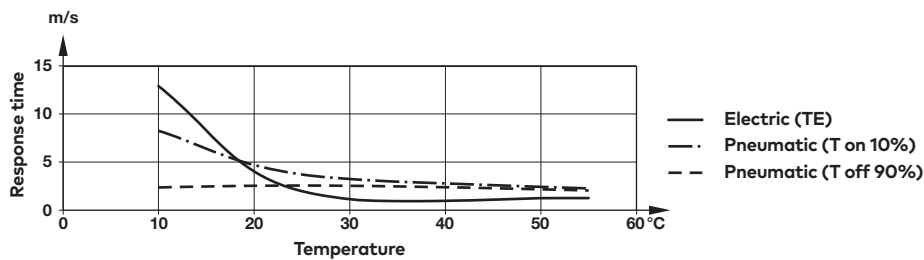

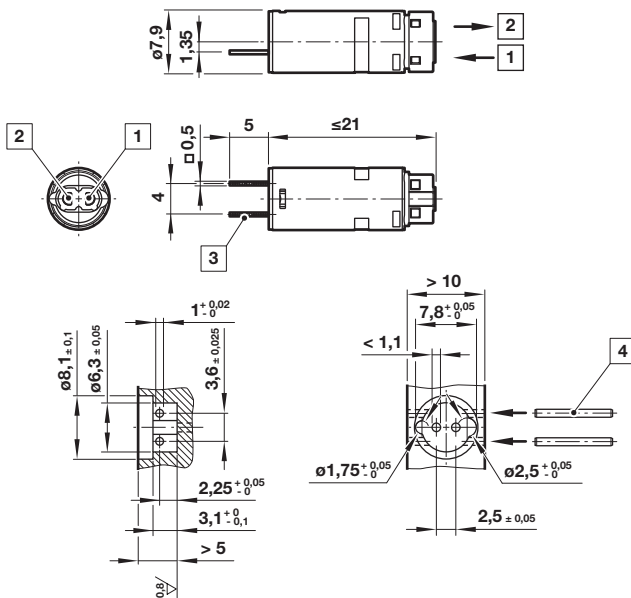
Dimensions
① Cartridge valve

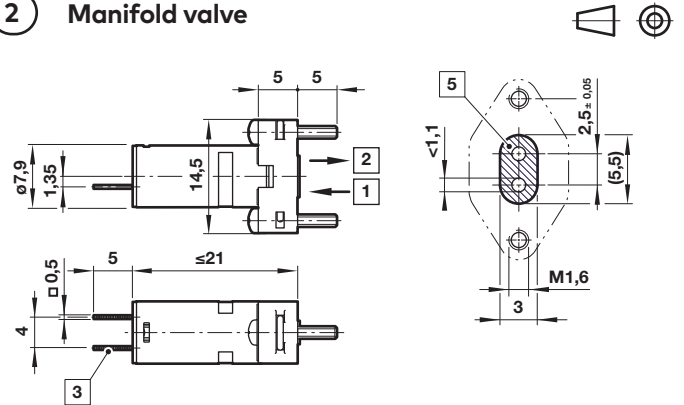
② Manifold valve

 Dimensions in mm
 Projection/First angle

- ① Inlet port
- ② Outlet port
- ③ Do not weld
- ④ Pins $\varnothing 1 \text{ h}8 \times >10$ (ISO 2338) not in scope of delivery
- ⑤ Sealing area

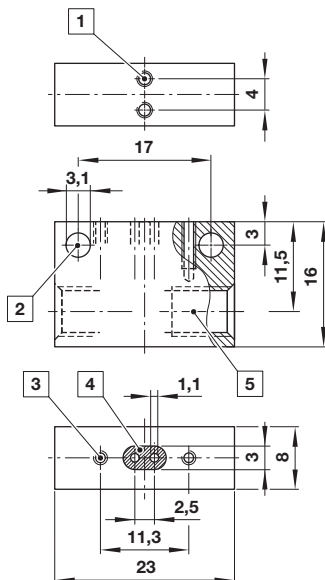
All valves are supplied with gasket.
 Mounting screws are in scope of delivery for manifold valve as well.

Manifold
Model: S140.0361 (M5); S140.0362 (1/4-28 UNF) (PEEK)

- ① Threads for mounting screws - M2 x 5 mm deep
- ② Mounting hole
- ③ Threads to fix valve in position - M1,6 x 6 mm deep
- ④ Sealing surface
- ⑤ Port size M5 or 1/4-28 UNF

Warning

These products are intended for use in industrial compressed air and neutral gas systems only. Do not use these products where pressures and temperatures can exceed those listed under »**Technical features/data**«.

Before using these products with fluids other than those specified, for non-industrial applications, life-support systems, or other applications not within published specifications, consult IMI Precision Engineering, Fluid Automation Systems s.a.

Through misuse, age, or malfunction, components used in fluid power systems can fail in various modes.

The system designer is warned to consider the failure modes of all component parts used in fluid power systems and to provide adequate safeguards to prevent personal injury or damage to equipment in the event of such failure.

System designers must provide a warning to end users in the system instructional manual if protection against a failure mode cannot be adequately provided.

System designers and end users are cautioned to review specific warnings found in instruction sheets packed and shipped with these products.